

THERMOSTATIC SHOWER VALVE - NGT902

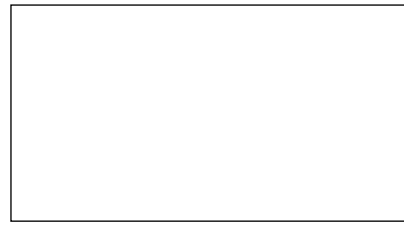

Min. working pressure 0.1bar

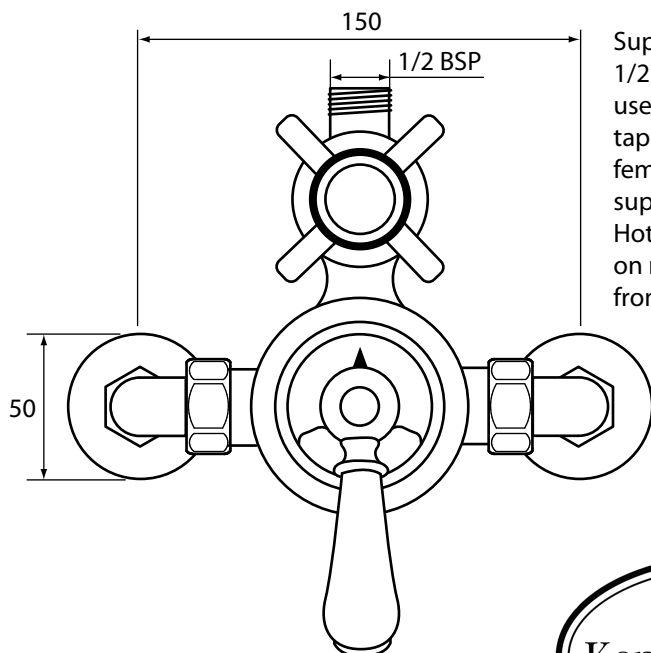
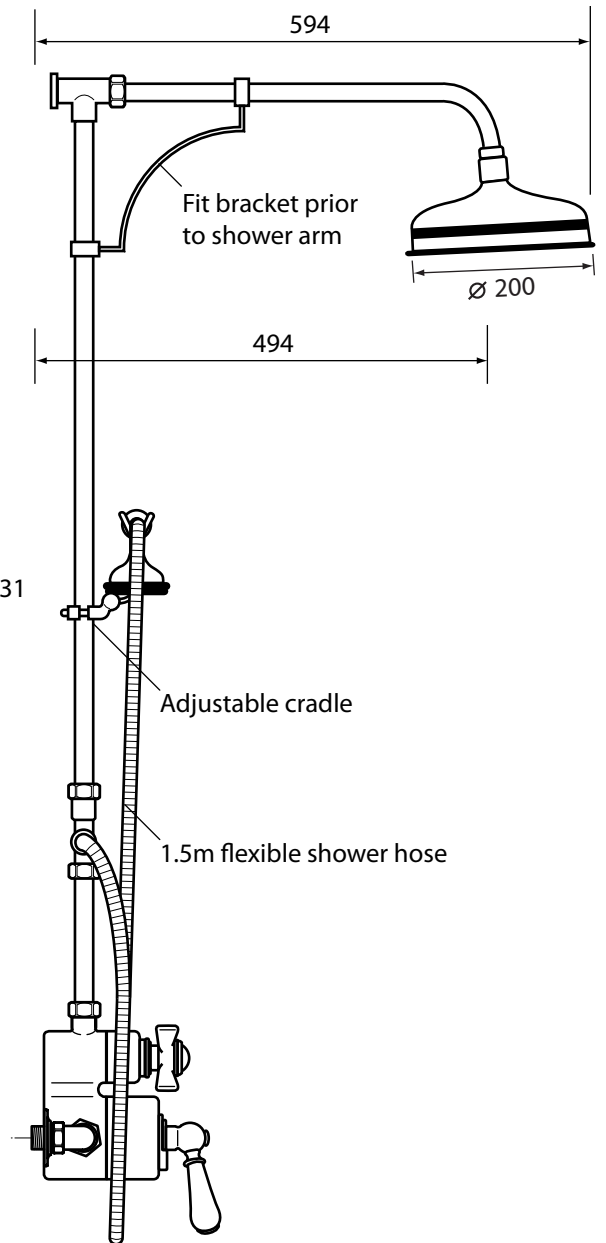
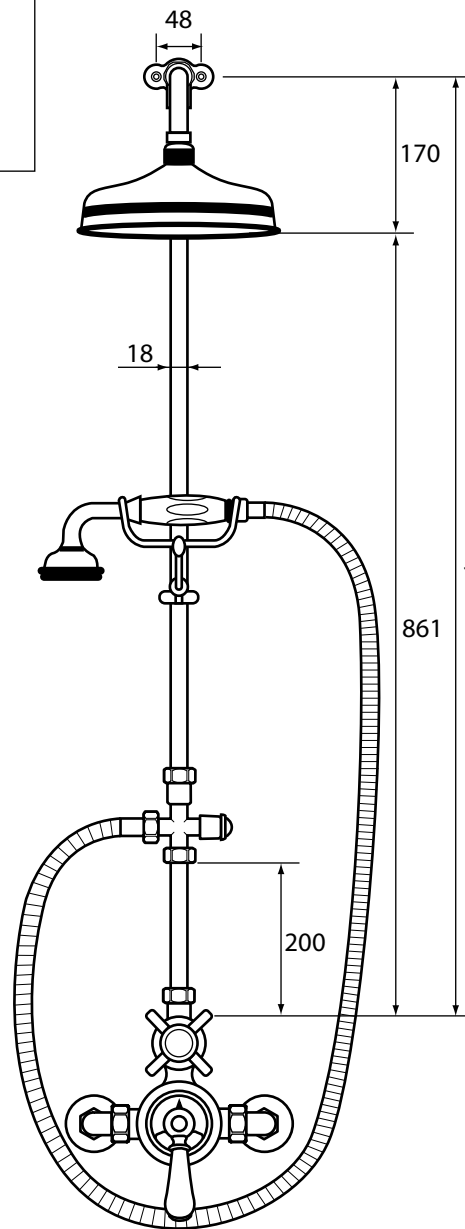

Supply connections
1/2" BSP MALE, for
use with sealant
tape into pre-fitted
female sockets (not
supplied).
Hot is on left, cold is
on right (viewed
from front).

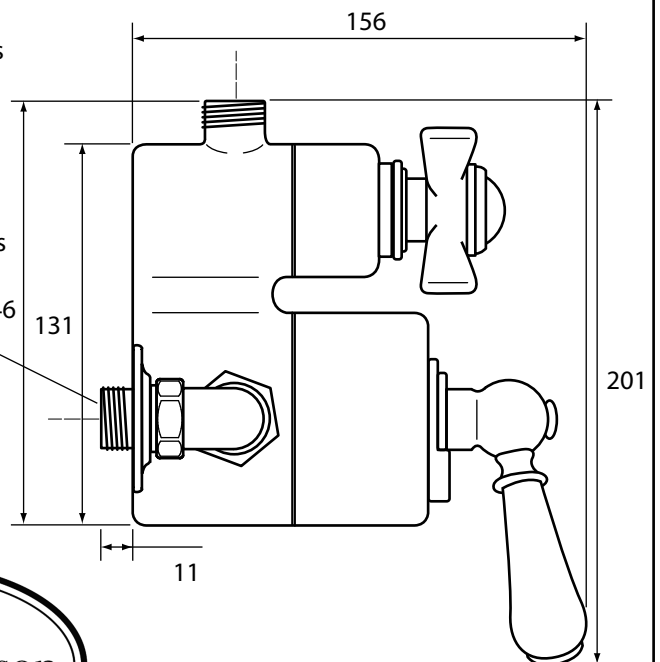

Technical specification
Drawings not to scale. All dimensions are nominal (mm).
We reserve the right to alter specifications without notice.