

# SINGLE LEVER SHOWER VALVE - NGT901

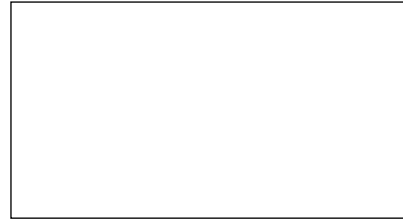

Min. working pressure 0.1bar

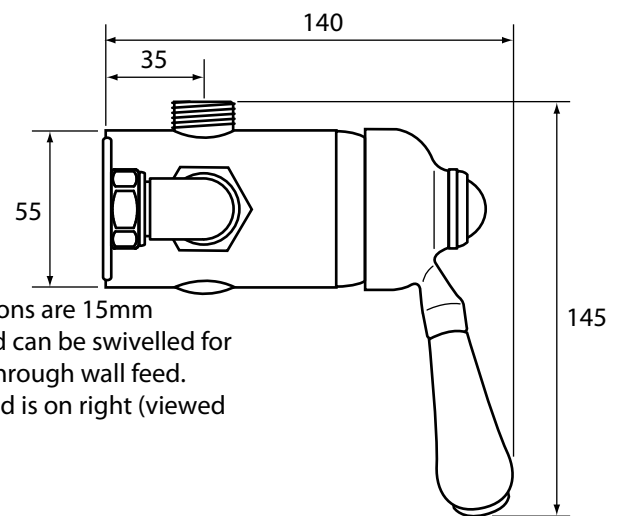
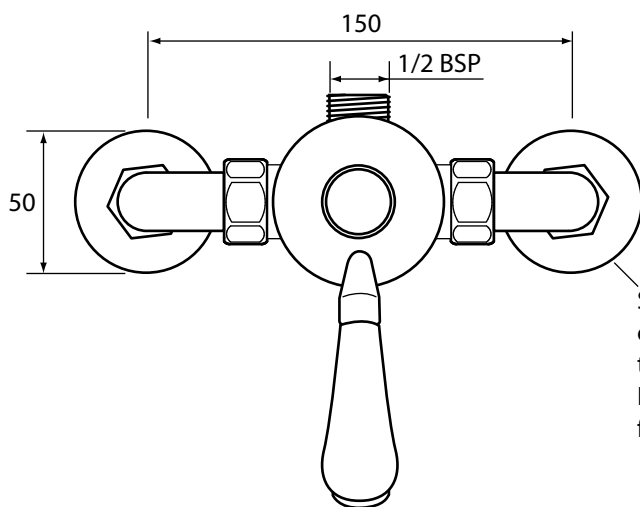
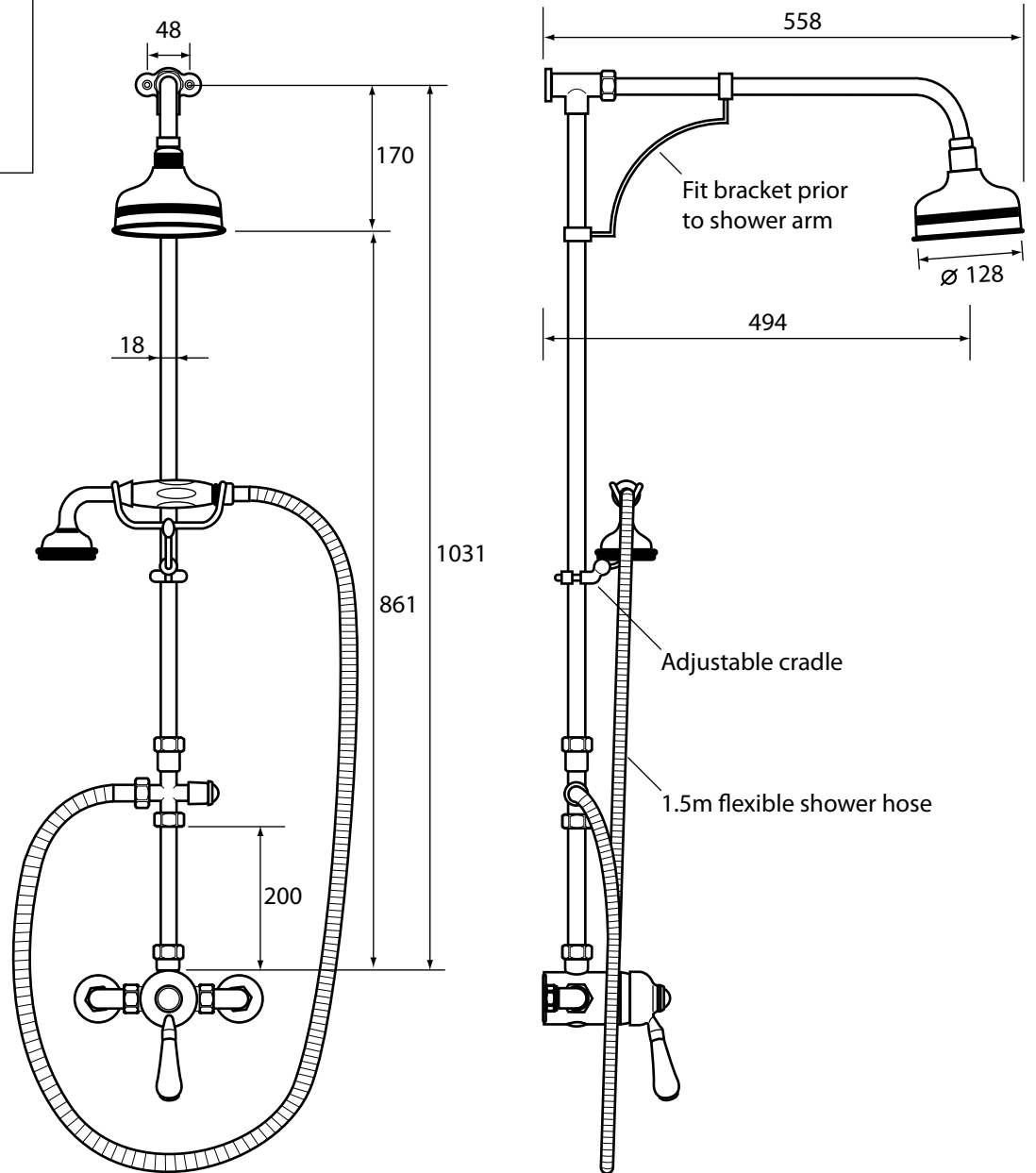

Supply connections are 15mm compression and can be swivelled for top, bottom or through wall feed. Hot is on left, cold is on right (viewed from front).



**Technical specification**

Drawings not to scale. All dimensions are nominal (mm). We reserve the right to alter specifications without notice.